

FOOT VALVE (FLANGED END)

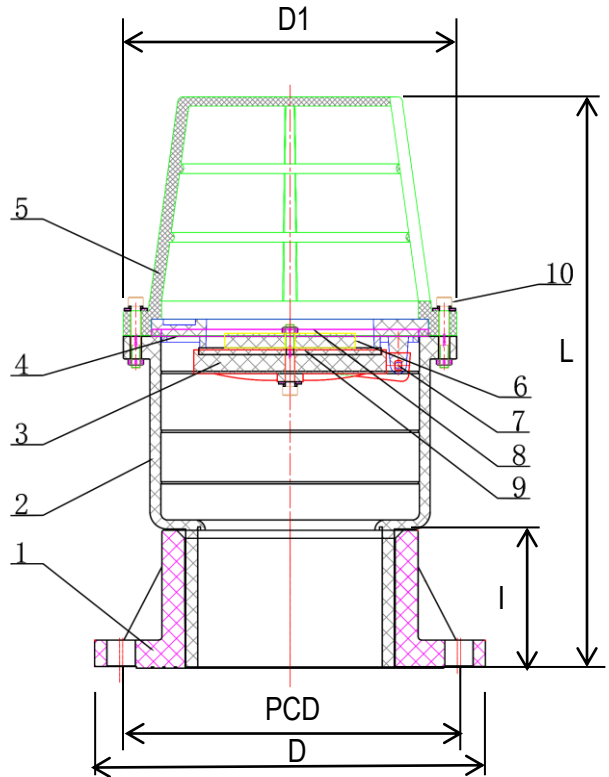

• END CONNECTOR: FLANGE



COMPONENT PARTS

ITEM	PARTS	MATERIAL	QTY
1	Flange	PVC	1
2	Upper Body	PVC	1
3	Spool	PVC	1
4	Spool Seat	PVC	1
5	Connector	PVC	1

COMPONENT PARTS

ITEM	PARTS	MATERIAL	QTY
6	Spool Fixing Plate	PVC	1
7	Seal	EPDM, FPM(NBR)	1
8	Gasket	EPDM, FPM(NBR)	1
9	Pin	AISI314	1
10	Fixings	AISI304	13

DIMENSIONS

SKU	JIS D(mm)	PN10 D(mm)	PCD (mm)	Bolt Hole N-Ø	D1 (mm)	I (mm)	L (mm)	WEIGHT (kg)	PCS/ CTN
FVAWE200F	330	/	290	12-23	341.0	102.5	499.2	20.2	2
FVAWE200FPN10	/	335	295	8-23	341.0	102.5	499.2	20.2	2