

## TRUE UNION BALL VALVE

- END CONNECTOR: THREAD, SOCKET
- WORKING PRESSURE: 150PSI

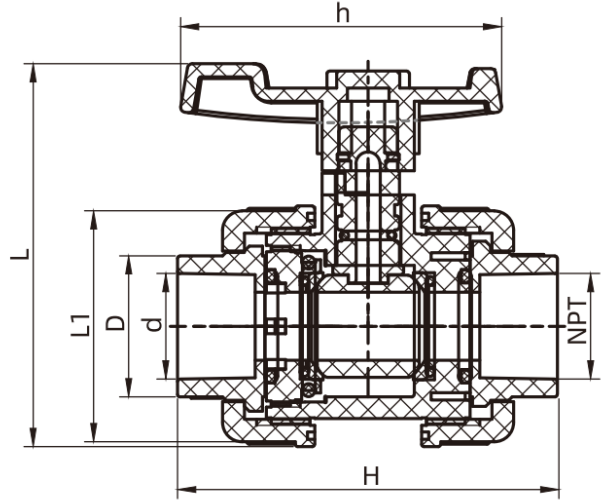

### COMPONENT PARTS

ITEM	PARTS	MATERIAL	QTY
1	Stem	PVC, CPVC, PP	1
2	Handle	ABS	1
3	Stem O-Ring	EPDM, FPM(NBR)	2
4	Union Nut	PVC, CPVC, PP	2
5	End Connector	PVC, CPVC, PP	2
6	Body O-Ring	EPDM, FPM(NBR)	2

### COMPONENT PARTS

ITEM	PARTS	MATERIAL	QTY
7	O-Ring	EPDM, FPM(NBR)	2
8	Body	PVC, CPVC, PP	1
9	Ball	PVC, CPVC, PP	1
10	Seat Seal	PTFE	2
11	Seat Carrier	PVC, CPVC, PP	1
12	Carrier O-Ring	EPDM, FPM(NBR)	1

### DIMENSIONS

SKU	NPT	BSPT	JIS	BS	ANSI	DIN	D	d	L	L1	H	h	WEIGHT (kg)	PCS/CTN
	Thd./in	Thd./in	d1(mm)	d1(mm)	d1(mm)	d1(mm)	(mm)	(mm)	(mm)	(mm)	(mm)	(mm)		
BVAWEU015	14.0	14	22	22	21.34	20	29.0	21.7	78.8	47.5	78.6	66.2	0.123	70
BVAWEU020	14.0	14	26	26	26.67	25	35.0	27.2	88.8	58.1	88.4	76.2	0.190	50
BVAWEU025	11.5	11	32	34	33.40	32	42.9	32.4	100.6	65.5	101.6	86.8	0.280	30
BVAWEU035	11.5	11	38	42	42.16	40	52.0	40.4	127.2	80.0	128.2	109.9	0.475	38
BVAWEU042	11.5	11	48	48	48.26	50	62.0	48.0	136.1	91.1	142.2	136.1	0.642	30
BVAWEU050	11.5	11	60	60	60.33	63	75.7	60.5	160.6	112.1	168.5	144.9	1.133	12
BVAWEU065	8.0	11	76	76	73.03	75	87.7	75.5	200.0	135.6	217.0	181.7	1.650	6
BVAWEU080	8.0	11	89	89	88.90	90	105.7	90.5	228.3	163.0	242.0	207.3	3.060	2
BVAWEU100	8.0	11	114	114	114.30	110	75.7	60.5	160.6	112.1	168.5	144.9	5.145	2